

Lumber conveyor chains & attachments

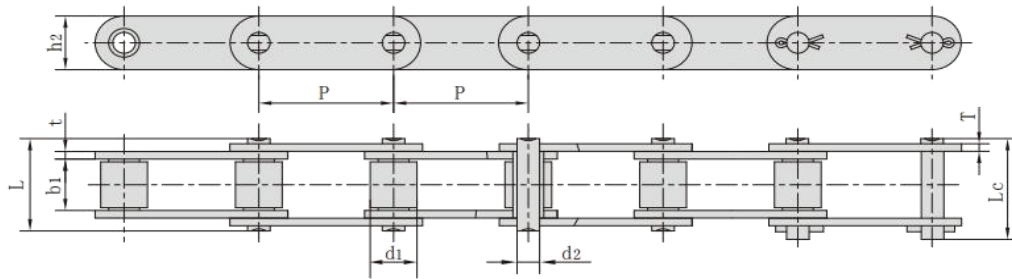

Chain No.	Pitch	Roller diameter	Width between inner plates	Pin diameter	Pin length		Inner plate depth	Plate thickness	Tensile strength	Average tensile strength	Weight per meter
	P	d1 max	b1 min	d2 max	L max	Lc max	h2 max	t/T max	Q Min	Q0	q
	mm	mm	mm	mm	mm	mm	mm	mm	kN/lbf	kN	kg/m
P42.47F1	42.47	22.20	27.00	11.10	49.0	53.5	28.60	4.00	97.0/21806	106.7	4.74
500R	50.00	25.40	25.40	14.63	52.0	56.4	40.00	5.00	100.0/22727	114.5	7.13
500RF1	50.00	25.40	25.40	14.63	53.4	60.1	40.00	5.00	120.0/29376	132.0	7.23
81X	66.27	23.00	27.00	11.10	49.0	53.5	28.50	4.00	106.7/24250	128.9	3.78
81XF14	66.27	23.00	27.00	11.10	50.8	53.8	28.70	4.00	85.5/19426	91.4	3.78
81XH	66.27	23.00	27.78	11.10	60.7	65.1	31.35	7.94/5.55	151.9/34523	175.7	5.88
81XHE	66.27	22.20	27.00	11.10	59.5	63.0	28.50	6.30	83.3/18927	89.1	5.09
81XHH	66.27	23.00	27.78	11.10	65.6	70.0	31.35	7.94	191.1/43432	212.6	6.70
81XHS	66.27	23.00	27.00	11.10	63.6	68.0	31.80	7.60	152.0/34545	177.2	6.55
441.100R	100.00	25.40	25.40	14.63	52.0	56.4	40.00	5.00	100.0/22727	114.5	5.15
P100F271	100.00	25.40	25.40	14.63	54.0	58.0	40.00	5.00	100.0/22480	110.0	5.22

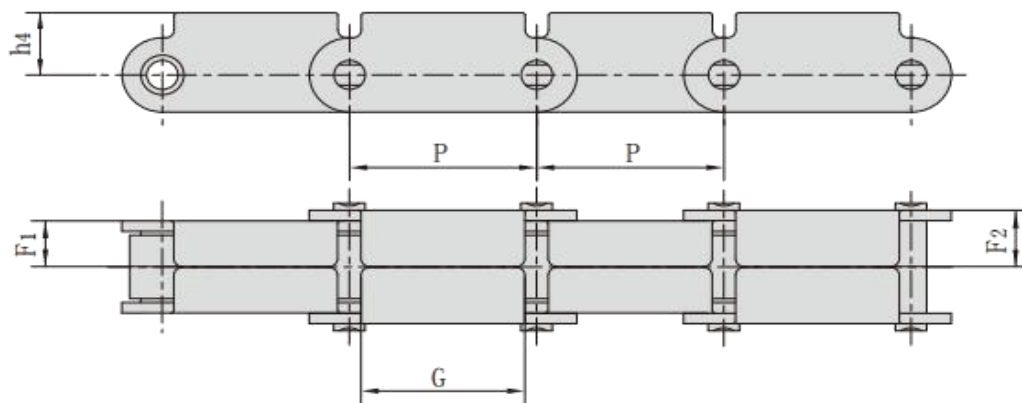

Chain No.	P mm	F1 mm	F2 mm	G mm	h4 mm
81XF1(RT)	66.27	17.50	21.80	58.00	23.85

Lumber conveyor chains & attachments

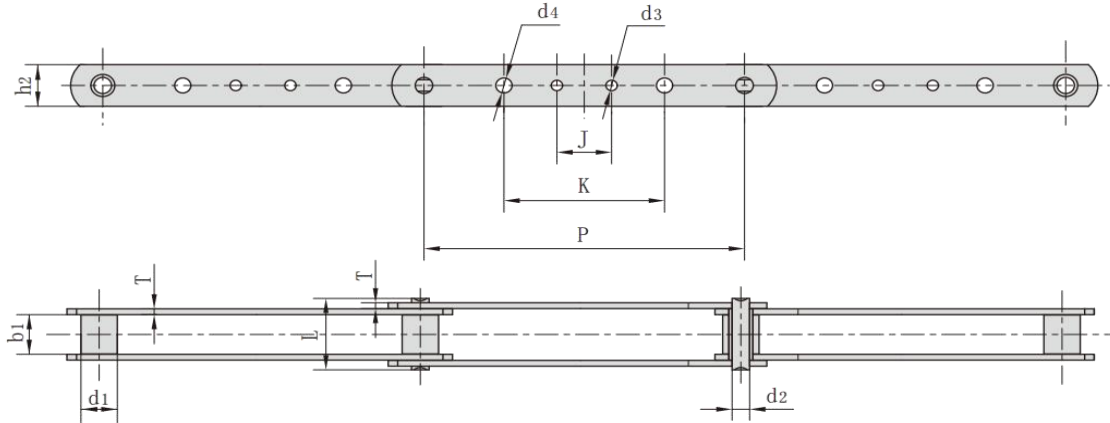

Chain No.	Pitch	Roller diameter	Width between inner plates	Pin dimension		Plate dimension					Plate thickness	Tensile strength	Average tensile strength	Weight per meter
	P	d1 max	b1 min	d2 max	L max	h2 max	d3 max	d4 max	J max	K max	T max	Q min	Q0	q
	mm	mm	mm	mm	mm	mm	mm	mm	mm	mm	mm	kN/lbf	kN	kg/m
3939-B4	203.2	23.0	27.0	11.1	49.0	28.58	7.2	7.2	38.1	101.6	4.0	115.58/26268	136.5	2.45
3939-B21	203.2	23.0	27.0	11.1	49.0	28.58	7.2	-	38.1	-	4.0	115.58/26268	136.5	2.45
3939-B23	203.2	23.0	27.0	11.1	49.0	28.58	-	10.3	-	92.1	4.0	115.58/26268	136.5	2.45
3939-B24	203.2	23.0	27.0	11.1	49.0	28.58	-	7.2	-	101.6	4.0	115.58/26268	136.5	2.48
3939-B40	203.2	23.0	27.0	11.1	49.0	28.58	-	10.3	-	101.6	4.0	115.58/26268	136.5	2.45
3939-B43	203.2	23.0	27.0	11.1	49.0	28.58	7.2	10.3	38.1	92.1	4.0	115.58/26268	136.5	2.42
3939-B44	203.2	23.0	27.0	11.1	49.0	28.58	7.2	10.3	38.1	101.6	4.0	115.58/26268	136.5	2.45
3939H-B4	203.2	23.0	27.0	11.1	58.0	28.60	-	7.2	38.0	102.0	6.4	150.00/34082	172.5	3.51

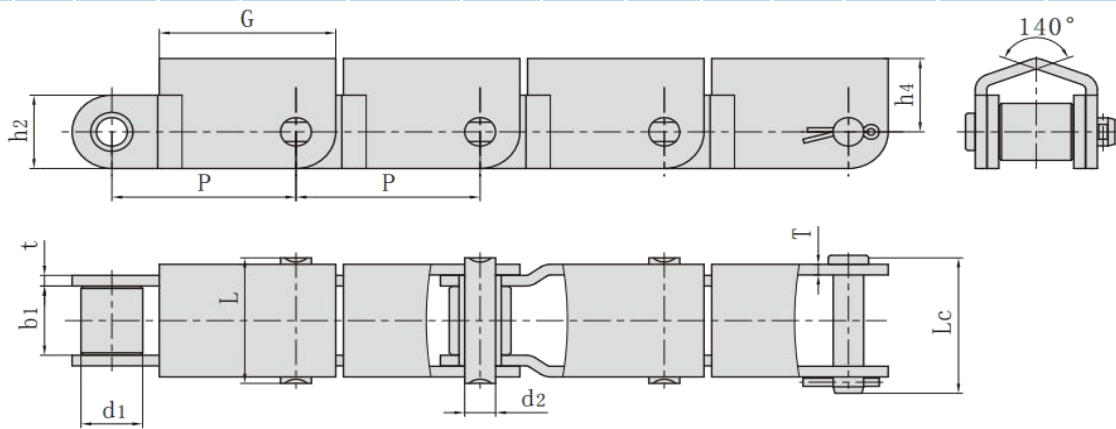

Chain No.	Pitch	Roller diameter	Width between inner plates	Pin dimension	Pin length		Plate dimension				Tensile strength	Weight per meter
	P	d1 max	b1 min	d2 max	L max	Lc max	h2 max	t/T max	G	h4	Q min	q
	mm	mm	mm	mm	mm	mm	mm	mm	mm	mm	kN/lbf	kg/m
P66.7F6	66.27	22.23	27.00	11.10	49.00	53.80	28.60	4.15	63.50	28.60	97.8/21985	5.25